



Alouette II Astazou

VOUGHT HELICOPTER INCORPORATED
LTV AEROSPACE CORPORATION

THIS IS THE VERSATILE **Alouette II Astazou**

A TRUE FIVE-PLACE HELICOPTER

Exceptional cabin spaciousness provides extra wide seating for five, or the capability to carry extremely bulky loads. Wide doors and no center posts contribute significantly to loading and unloading ease.

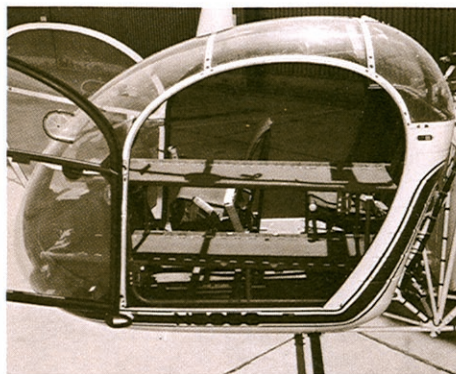
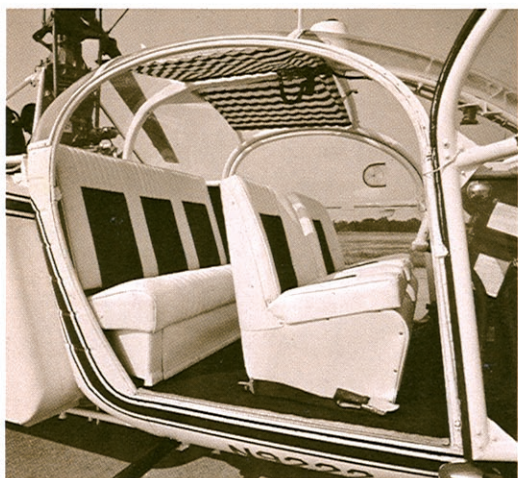

THE ALOUETTE II IS A PERFECT AMBULANCE.

With separate folding rear bench and removable front seat, a dual litter configuration can be installed in a matter of minutes.

EXTREMELY LOW MAINTENANCE

—All maintenance — daily, unscheduled, periodic, and the 1,400 hour airframe overhaul — requires less than 1/2 manhour per flying hour.

LARGE PAYLOAD

A cargo space of 60 cubic feet provides for over 1,100 pounds of internal cargo capacity. When using an external sling, loads in excess of 1,300 pounds may be carried. Also available are external side carriers with an 881 pound capacity and an external hoist capable of lifting 264 pounds.

RELIABLE ASTAZOU POWER

The Alouette II has power to spare from its rugged Astazou II A fixed shaft turbine engine rated at 523 shp. The engine provides 35% more power than that required for sea level operations, and at least 65% more horsepower than any other helicopter in its class.

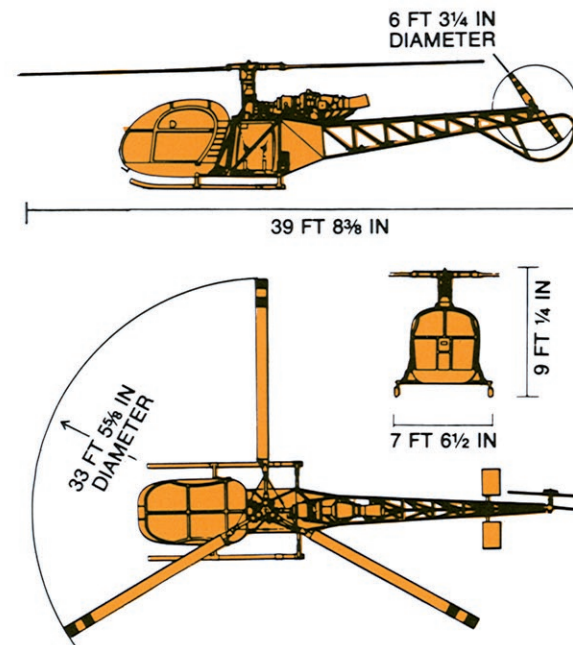

PERFORMANCE —

S.L. Std. Conditions at Gross Weight of .	2,980	3,650
Useful Load, lb.	990	1,660
Maximum Speed at SL (VNE), MPH . . .	127	127
Cruise Speed at SL, MPH	116	112
Maximum Rate of Climb at SL, FPM . . .	1,733	1,320
Service Ceiling, Feet.	14,800	10,900
Maximum Range at SL, Miles	444	430
Endurance at SL, Hours	5.4	5.3

WEIGHTS

Empty weight, lb	1,990
Useful load, lb	1,660
Maximum gross, lb	3,650



**VOUGHT
HELICOPTER
INCORPORATED**

1507 PACIFIC AVENUE
DALLAS, TEXAS 75201